



BUILDING CODE COMPLIANCE OFFICE (BCCO)
PRODUCT CONTROL DIVISION

MIAMI-DADE COUNTY, FLORIDA
METRO-DADE FLAGLER BUILDING
140 WEST FLAGLER STREET, SUITE 1603
MIAMI, FLORIDA 33130-1563
(305) 375-2901 FAX (305) 375-2908

www.miamidade.gov/buildingcode

NOTICE OF ACCEPTANCE (NOA)

La Finestra, L.C.
2790 N.W. 104 Court
Miami, FL 33172

SCOPE:

This NOA is being issued under the applicable rules and regulations governing the use of construction materials. The documentation submitted has been reviewed by Miami-Dade County Product Control Division and accepted by the Board of Rules and Appeals (BORA) to be used in Miami Dade County and other areas where allowed by the Authority Having Jurisdiction (AHJ).

This NOA shall not be valid after the expiration date stated below. The Miami-Dade County Product Control Division (In Miami Dade County) and/or the AHJ (in areas other than Miami Dade County) reserve the right to have this product or material tested for quality assurance purposes. If this product or material fails to perform in the accepted manner, the manufacturer will incur the expense of such testing and the AHJ may immediately revoke, modify, or suspend the use of such product or material within their jurisdiction. BORA reserves the right to revoke this acceptance, if it is determined by Miami-Dade County Product Control Division that this product or material fails to meet the requirements of the applicable building code.

This product is approved as described herein, and has been designed to comply with the Florida Building Code, including High Velocity Hurricane Zone of the Florida Building Code.

DESCRIPTION: Series "EKU-53" Outswing Aluminum French Door – L.M.I.

APPROVAL DOCUMENT: Drawing No. FIN-EKU, titled "EKU-53 Aluminum Outswing Entrance Door", sheets 1 through 10 of 10, dated 03/16/10 and last revised on AUG 27, 2010, prepared by Bromley-Cook Engineering, Inc., signed and sealed by William D. Cook, P. E., bearing the Miami-Dade County Product Control Revision stamp with the Notice of Acceptance number and expiration date by the Miami-Dade County Product Control Division.

MISSILE IMPACT RATING: Large and Small Missile Impact Resistant

Limitation:

1. Approved Vertical and Horizontal mullions under separate approval. Mullion end load and anchorage requirements to be reviewed by AHJ.

LABELING: Each unit shall bear a permanent label with the manufacturer's name or logo, city, state and following statement: "Miami-Dade County Product Control Approved", unless otherwise noted herein.

RENEWAL of this NOA shall be considered after a renewal application has been filed and there has been no change in the applicable building code negatively affecting the performance of this product.

TERMINATION of this NOA will occur after the expiration date or if there has been a revision or change in the materials, use, and/or manufacture of the product or process. Misuse of this NOA as an endorsement of any product, for sales, advertising or any other purposes shall automatically terminate this NOA. Failure to comply with any section of this NOA shall be cause for termination and removal of NOA.

ADVERTISEMENT: The NOA number preceded by the words Miami-Dade County, Florida, and followed by the expiration date may be displayed in advertising literature. If any portion of the NOA is displayed, then it shall be done in its entirety.

INSPECTION: A copy of this entire NOA shall be provided to the user by the manufacturer or its distributors and shall be available for inspection at the job site at the request of the Building Official.

This NOA revises NOA # 08-1126.02 consists of this page 1 and evidence pages E-1 & E2, as well as approval document mentioned above.

The submitted documentation was reviewed by Ishaq I. Chanda, P.E.



NOA No 10-0511.03
Expiration Date: February 27, 2013
Approval Date: September 15, 2010
Page 1

9/11/10

NOTICE OF ACCEPTANCE: EVIDENCE SUBMITTED

A. DRAWINGS

1. Manufacturer's die drawings and sections. (transferred from file # 08-1126.02)
2. Drawing No. **FIN-EKU**, titled "EKU-53 Aluminum Outswing Entrance Door", sheets 1 through 10 of 10, dated 03/16/10 and last revised on AUG 27, 2010, prepared by Bromley-Cook Engineering, Inc., signed and sealed by William D. Cook, P.E.

B. TESTS

1. Test reports on
 - 1) Air Infiltration Test, per FBC, TAS 202-94
 - 2) Uniform Static Air Pressure Test, Loading per FBC, TAS 202-94
 - 3) Water Resistance Test, per FBC, TAS 202-94
 - 4) Forced Entry Test, per FBC 2411 3.2.1 and TAS 202-94
 - 5) Large Missile impact Test per FBC, TAS 201-94
 - 6) Cyclic Wind Pressure Loading per FBC, TAS 203-94

Along with marked-up drawings and installation diagram of aluminum outswing French Door, prepared by Hurricane Engineering & Testing Lab., Test Report No. **HETI-09-2676**, **HETI-09-2677**, **HETI-10-3002**, **HETI-10-3003**, **HETI-10-3009** and **HETI-10-3010**, all dated 04/06/2010, all signed and sealed by Candido Font, P. E.

2. Additional Test reports on (transferred from file # 08-1126.02)
 - 1) Air Infiltration Test, per FBC, TAS 202-94
 - 2) Uniform Static Air Pressure Test, Loading per FBC, TAS 202-94
 - 3) Water Resistance Test, per FBC, TAS 202-94
 - 4) Forced Entry Test, per FBC 2411 3.2.1 and TAS 202-94
 - 5) Large Missile impact Test per FBC, TAS 201-94
 - 6) Cyclic Wind Pressure Loading per FBC, TAS 203-94

Along with marked-up drawings and installation diagram of aluminum outswing French Door, prepared by Hurricane Engineering & Testing Lab., Test Report No. **HETI-08-2076A & B**, **HETI-08-2163**, **HETI-08-2020** and **HETI-08-2005**, all dated 10/31/2008, all signed and sealed by Candido Font, P. E.

3. Additional Test reports on (transferred from file # 08-1126.02)
 - 1) Air Infiltration Test, per FBC, TAS 202-94
 - 2) Uniform Static Air Pressure Test, Loading per FBC, TAS 202-94
 - 3) Water Resistance Test, per FBC, TAS 202-94
 - 4) Forced Entry Test, per FBC 2411 3.2.1 and TAS 202-94
 - 5) Large Missile impact Test per FBC, TAS 201-94
 - 6) Cyclic Wind Pressure Loading per FBC, TAS 203-94

along with marked-up drawings and installation diagram of Aluminum Outswing French Door, prepared by Fenestration Testing Laboratory, Inc., Test Report No. **FTL-4531**, dated 06/01/05 and Test Report No. **FTL-3881**, dated 08/23/04, both signed and sealed by Edmundo Largaespada, P. E.

Ishaq I. Chanda

Ishaq I. Chanda, P.E.

Product Control Examiner

NOA No 10-0511.03

Expiration Date: February 27, 2013

Approval Date: September 15, 2010

NOTICE OF ACCEPTANCE: EVIDENCE SUBMITTED

C. CALCULATIONS

1. Anchor verification calculations complying w/ FBC-2007, dated 04-27-10 and last revised on 08/18/10, prepared by Bromley-Cook Engineering, Inc, signed and sealed by William D. Cook, P. E., P.E.
2. Glazing complies with ASTM E-1300-02 & -04

D. QUALITY ASSURANCE BY:

1. Miami-Dade Building Code Compliance Office (BCCO).

E. MATERIAL CERTIFICATIONS

1. Notice of Acceptance No. **09-0312.02** issued to E.I. DuPont DeNemours & Co., Inc. for their "**DuPont Butacite® PVB, Interlayer**", expiring on 12/11/10.

F. STATEMENTS

1. Statement letters of conformance and "No financial interest", both dated 04-26-10, prepared by Bromley-Cook Engineering, Inc, signed and sealed by William D. Cook, P. E.
2. Statement of compliance, issued as part of the above referenced test reports.

G. OTHER

1. This NOA revises NOA # **08-1126.02 (07-1107.04)**, expiring February 27, 2013.
2. Test Proposals dated 07/28/03 and 07/29/04 approved by BCCO.

Ishaq I. Chanda

Ishaq I. Chanda, P.E.

Product Control Examiner

NOA No 10-0511.03

Expiration Date: February 27, 2013

Approval Date: September 15, 2010

LA FINESTRA, LC

SERIES: EKU 53 OUTSWING FRENCH DOOR (HIGH LOAD)

GLASS CHART		
GLASS TYPE	MAXIMUM D.L.O.	MAX DESIGN LOAD
GL-1	30" W x 87" H	+110.0/-110.0 PSF
	27" W x 110" H	+80.0/-80.0 PSF
GL-2	27" W x 110" H	+80.0/-80.0 PSF

GLASS SCHEDULE LARGE MISSILE IMPACT RESISTANT	
GL-1	= 7/16" (.454") LAMINATED 3/16" (.182") HS -.090" P.V.B. INTERLAYER (DUPONT BUTACITE) - 3/16" HEAT STRENGTHENED
GL-2	= 1-1/4" INSULATED 3/16" (.182") HS -.090" P.V.B. 3/16" HS 1/2" AIR GAP 3/16" TEMPERED

MAX PANEL WIDTH
 DLO + 9" FOR DIE # 16012 (#2)
 DLO + 7.62" FOR DIE # 16013 (#2A)

MAX PANEL HEIGHT
 DLO + 9" FOR DIE # 16012 (#2)
 DLO + 7.62" FOR DIE # 16013 (#2A)

WATER INFILTRATION TEST PRESSURE
 - DOORS UP TO 96" TALL: 16.5 PSF
 - DOORS UP TO 120" TALL: 12 PSF
 WITH STANDRAD THRESHOLD

NOTE: ADA COMPLIANT THRESHOLD NOT APPROVED FOR WATER FILTRATION

TYPICAL CONFIGURATIONS

MAX. DOOR SIZES SHOWN

MULTIPLE UNITS STACKED SIDE BY SIDE
 MUST HAVE APPROVED MULLIONS BETWEEN EACH DOOR FRAME
 *(SEE ALTERNATE CONFIGURATIONS ON PAGE 2)

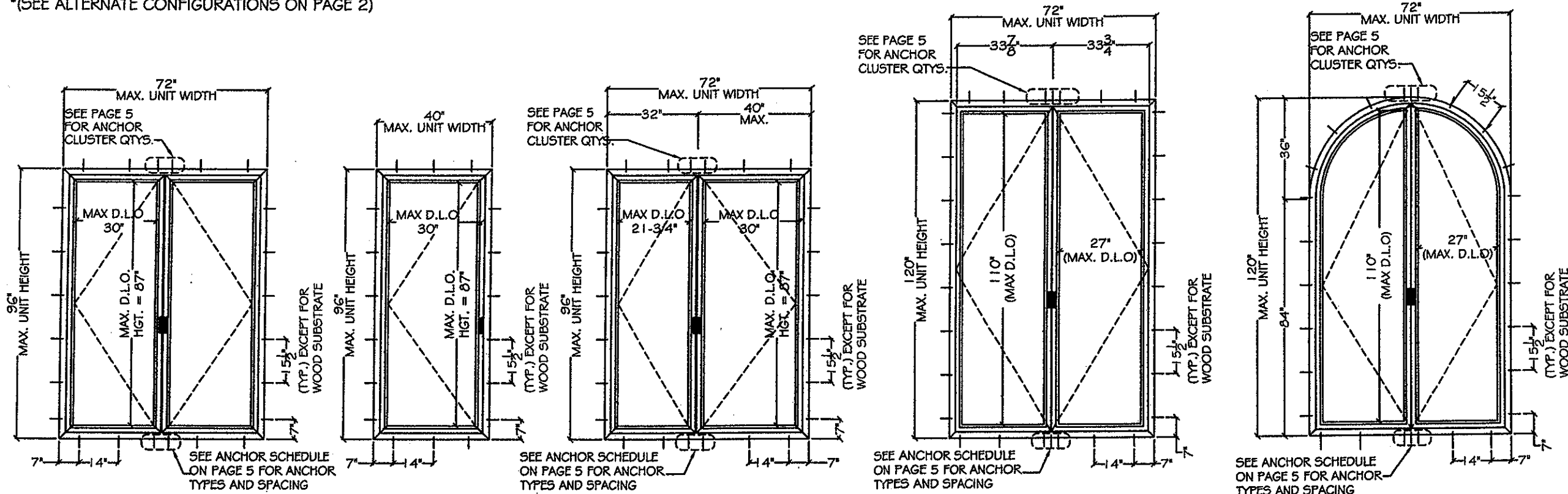

NOTES:

1. THIS SYSTEM HAS BEEN DESIGNED TO COMPLY WITH THE REQUIREMENTS OF THE HIGH VELOCITY HURRICANE ZONE AS DESCRIBED IN THE "2007 FLORIDA BUILDING CODE"
2. THIS WINDOW SYSTEM HAS BEEN TESTED, ENGINEERED AND APPROVED FOR DESIGN PRESSURES NOT TO EXCEED THOSE SHOWN IN SCHEDULE.
3. BUCK, OPENINGS & BUCK FASTENERS MUST BE DESIGNED & INSTALLED TO WITHSTAND WIND LOADS FOR EACH APPLICATION. THE DESIGN & ENGINEERING OF BUCKS SHALL BE PROVIDED BY "THE ENGINEER OF RECORD"
4. BUCK FASTENERS MAY NOT EXCEED 16" O.C. SPACING AROUND OPENINGS.
5. THE SYSTEM SHOWN HEREIN WAS TESTED FOR WATER, AIR, IMPACT, CYCLIC & UNIFORM STATIC AIR PRESSURE TESTING IN CONFORMANCE WITH DADE COUNTY PROTOCOLS TAS-201, 202 & 203.
6. ONE-THIRD INCREASE IN ALLOWABLE MATERIAL STRESS LIMITS FOR SHORT DURATION WIND LOAD NOT USED IN THE DESIGN CALCULATIONS, EXCEPT FOR (1.6) WIND LOAD FACTOR FOR WOOD.

PRODUCT REVISED
 as complying with the Florida
 Building Code
 Acceptance No 10-0511-03
 Expiration Date FEB 27, 2013
 By: *Isaac J. Chaudhry*
 Miami Dade Product Control
 Division

LA FINESTRA, L.C.
 ITALIAN WINDOWS & DOORS
 2790 N.W. 104 COURT
 Miami, FL 33172
 Phone (305) 599-8093
 Fax (305) 592-4671

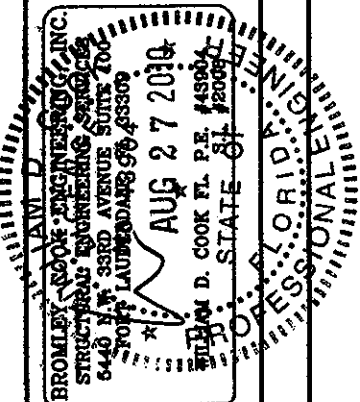
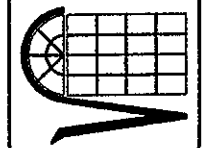

PRODUCT:
**EKU-53 IMPACT DOORS
 HIGH LOAD**

DATE: 03/16/2010
 SCALE: NTS.
 DWG. BY: LA FIN
 CHK. BY:
 DRAWING No.:
 FN-EKU53
 SHEET: 1 OF 10

ALTERNATE CONFIGURATIONS

UNITS MAY BE INSTALLED WITH A MIAMI-DADE COUNTY APPROVED MULLION BETWEEN EACH DOOR AND/OR FRAME. THE LOWEST DESIGN PRESSURE FOR THE DOOR, TRANSOM OR MULLION WILL CONTROL.

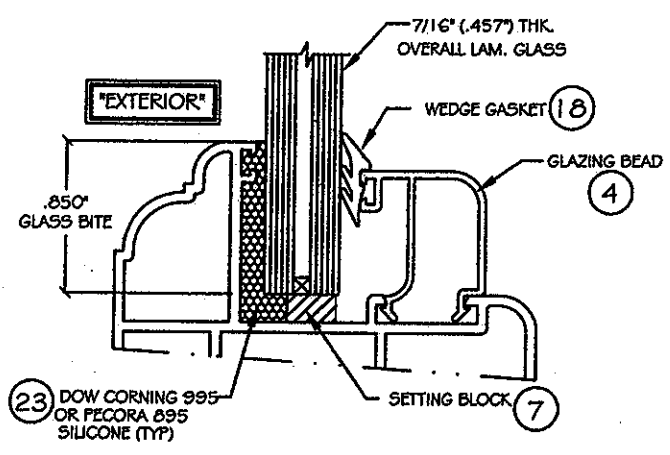
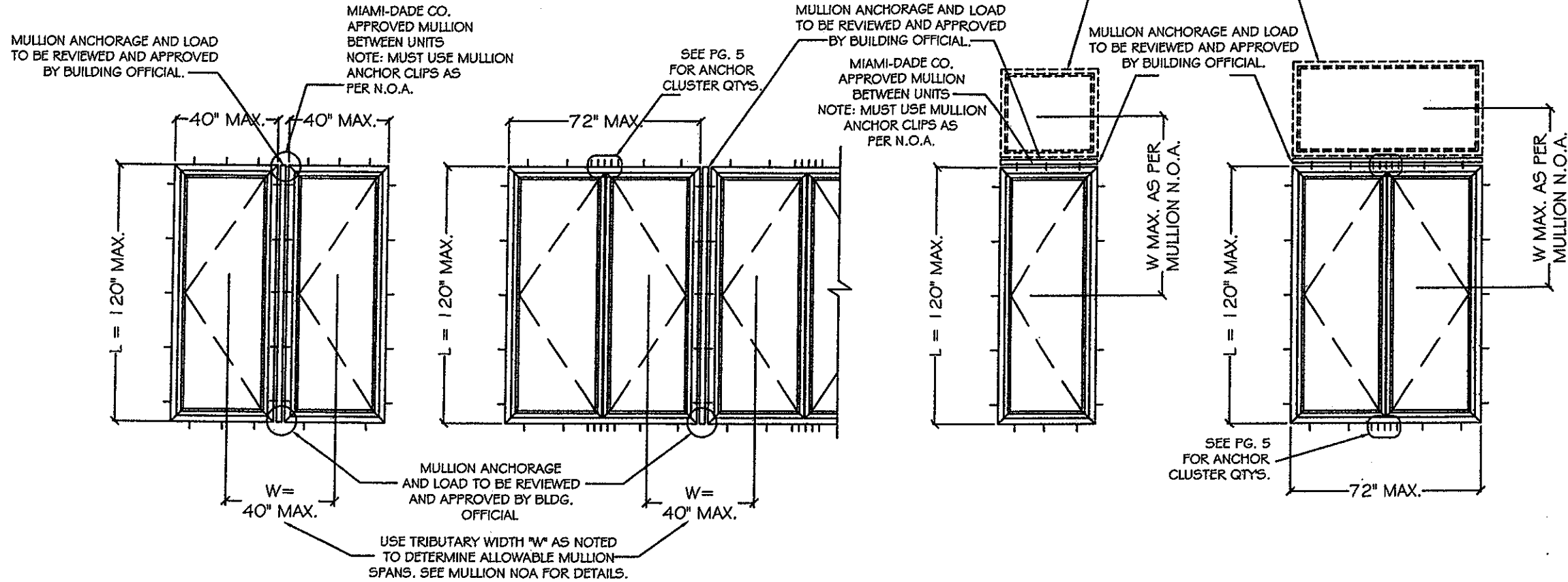

GLAZING DETAIL GL-1
SCALE: NTS.
MAX D.P. = +110 / -110 PSF

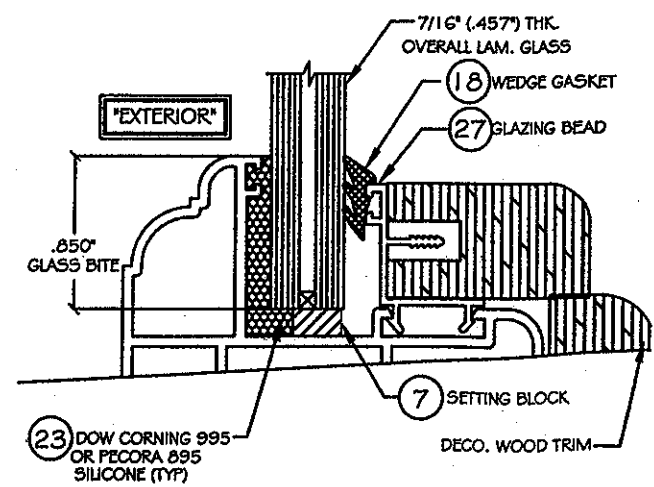

GLAZING DETAIL GL-1 (WITH WOOD TRIM)
SCALE: NTS. OPTION
MAX D.P. = +80 / -80 PSF

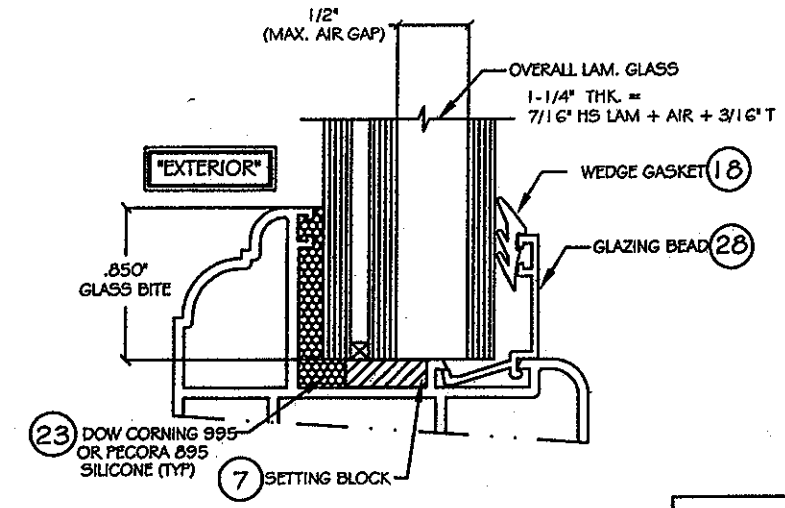

GLAZING DETAIL GL-2
SCALE: NTS. MAX D.P. = +80 / -80 PSF

PRODUCT REVISED
as complying with the Florida
Building Code
Acceptance No. 10-0511-03
Expiration Date Feb 27, 2013
By: *Yhas J. Chand*
Miami Dade Product Control
Division

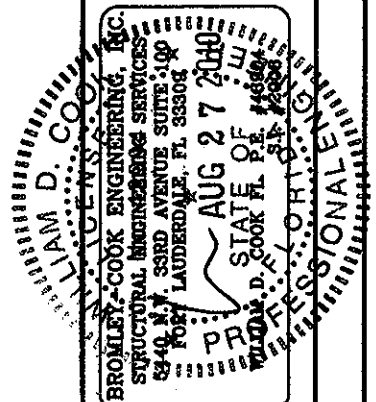

LA FINESTRA, L.C.
ITALIAN WINDOWS & DOORS
2790 NW 104 COURT
Miami, FL 33172
Phone (305) 599-8093
Fax (305) 592-4671

PRODUCT:
EKU-53 IMPACT DOORS
HIGH LOAD

DATE: 10/02/2009
SCALE: 3/8" = 1'-0"
DWG. BY: LA FIN
CHK. BY:
DRAWING No.:
FN-EKUS3
SHEET: 2 OF 10

SERIES EKU-53 ALUMINUM OUTSWING DOOR

(UNIT ELEVATIONS VIEWED FROM EXTERIOR)

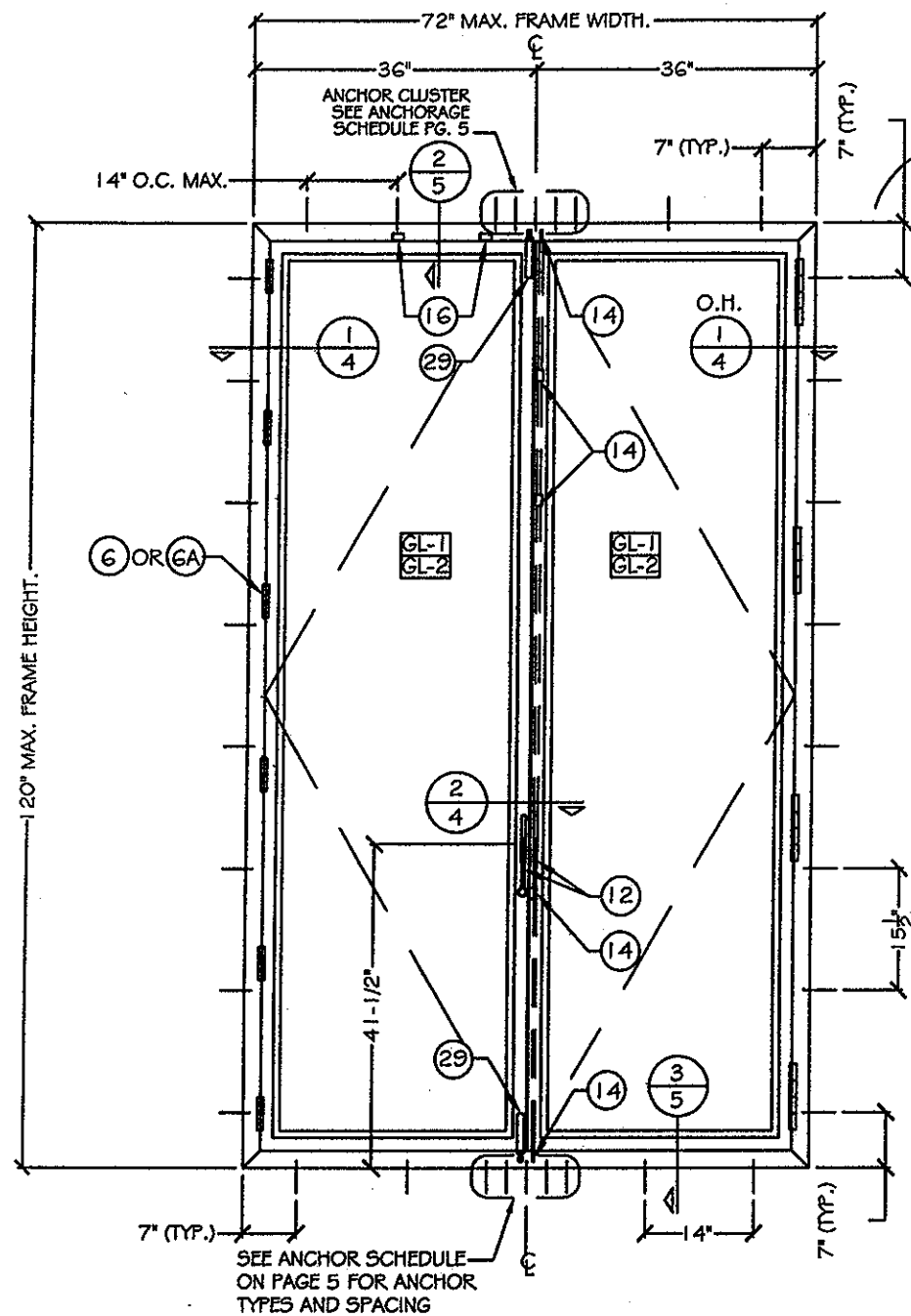

NOTE: FOR ODD NUMBER OF ANCHORS IN CLUSTER, INSTALL ONE ANCHOR IN CENTER OF INTERLOCK.

TYP. ANCHOR LOCATIONS @ HEAD & SILL

HARDWARE	
(12)	OPERATING HANDLE
(14)	5-POINT LOCKING SYSTEM
(16)	MUSHROOM HEAD AND KEEPERS
(29)	FLUSH BOLT
HINGES	
(6) OR (6A)	- 120" DOOR: FASTEN (8) PAIRS OF HINGES IN (4) "CLUSTERS" IN EACH PANEL OR (5) PAIR EQUALLY SPACED ON EACH PANEL
	- 96" DOOR: FASTEN (6) PAIRS OF HINGES IN (3) "CLUSTERS" IN EACH PANEL. OR (5) PAIRS EQUALLY SPACED ON EACH PANEL
GLAZING	
GL-1	GL-2
SEE ALLOWABLE GLASS DLO ON SHEET 1	

MAX. EXCEPT FOR WOOD SUBSTRATE (SEE ANCHOR SCHEDULE PG. 5)

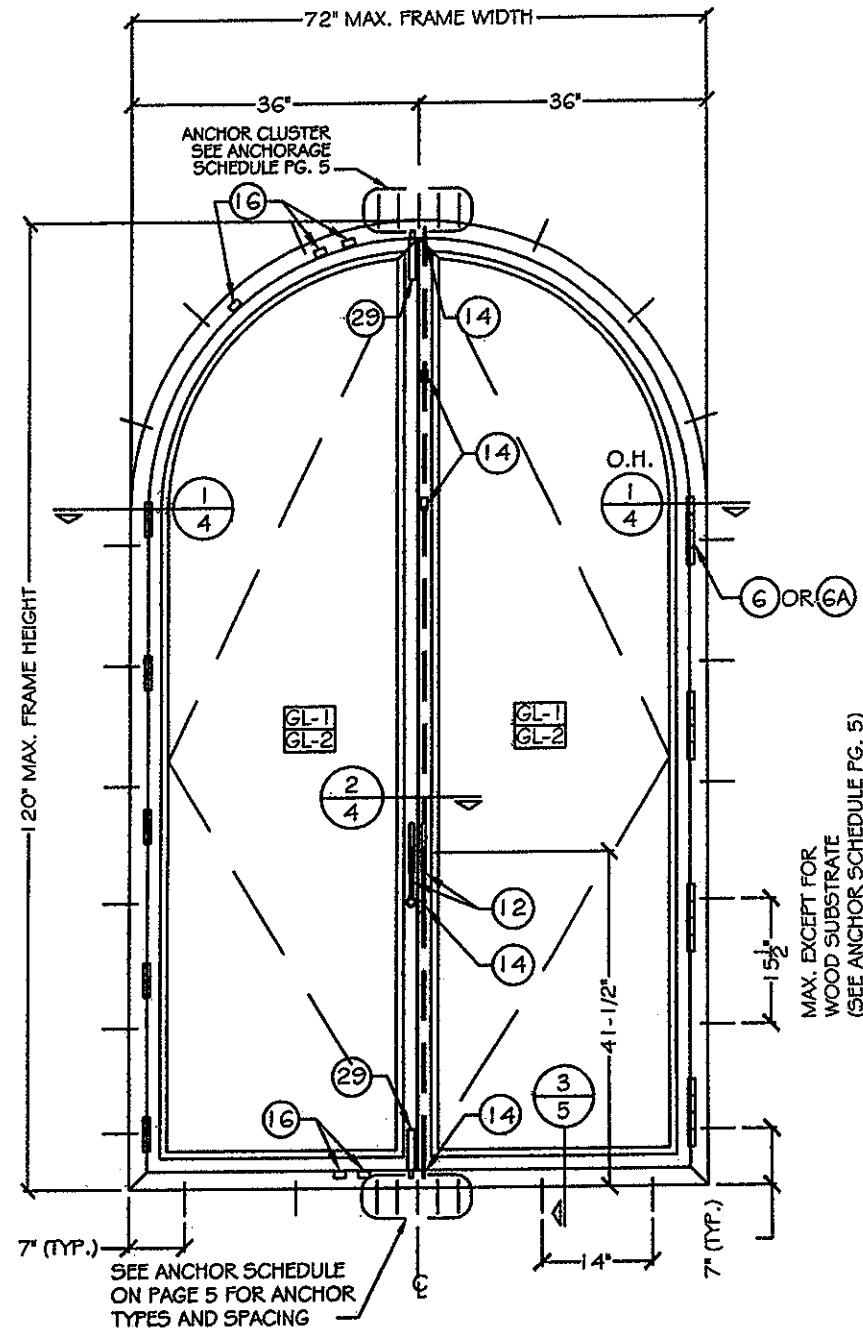

NOTE: FOR ODD NUMBER OF ANCHORS IN CLUSTER, INSTALL ONE ANCHOR IN CENTER OF INTERLOCK.

PRODUCT REVISED as complying with the Florida Building Code Acceptance No. 10-0511-03 Expiration Date FEB 27, 2013
By *William D. Cook*
Miami Dade Product Control Division

LA FINESTRA, L.C.
ITALIAN WINDOWS & DOORS
2790 NW 104 COURT
Miami, FL 33172
Phone (305) 599-8093
Fax (305) 592-4671

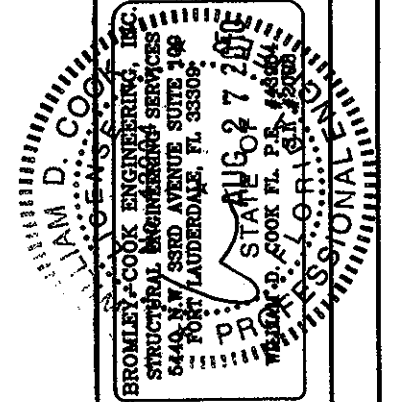
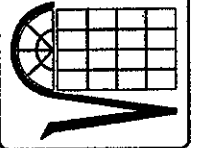

PRODUCT: EKU-53 IMPACT DOORS HIGH LOAD

DATE: 10/02/2008
SCALE: 1/2" = 1'-0"
DWG. BY: LA FIN
CHK. BY:
DRAWING No.: FN-EKU53
SHEET: 3 OF 10

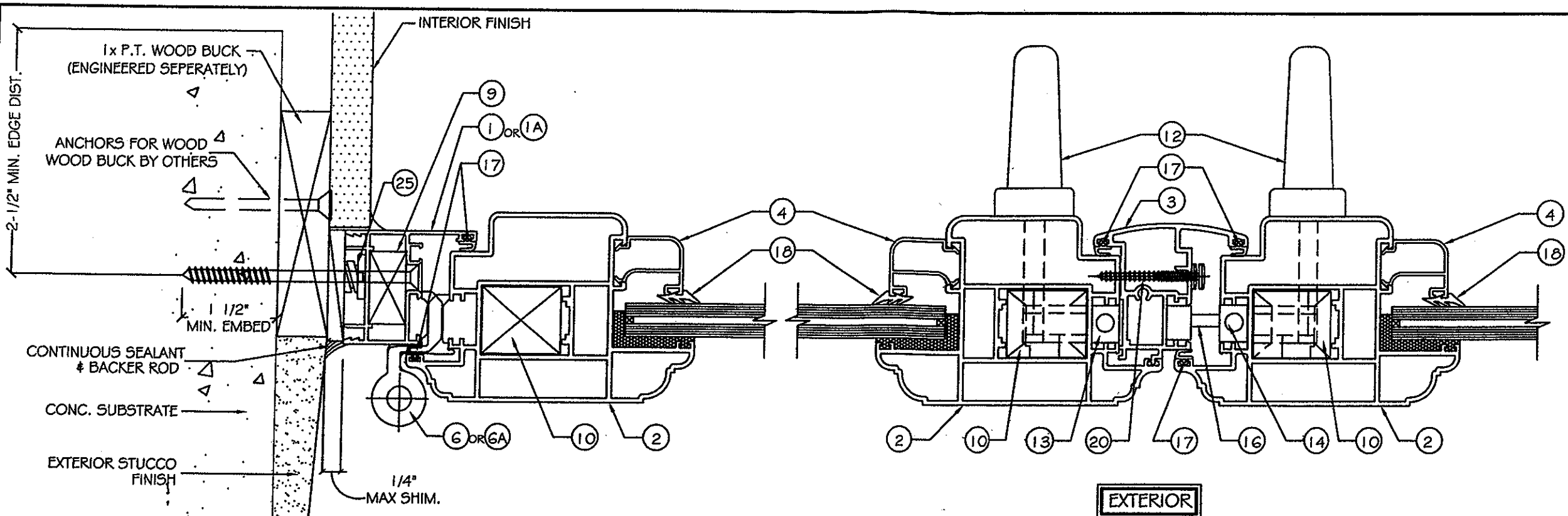

1 JAMB DETAIL (CONC. SUBSTRATE)
4 SCALE: 1/4" = 1'-0"

2 ASTRAGAL DETAIL
4 SCALE: 1/4" = 1'-0"

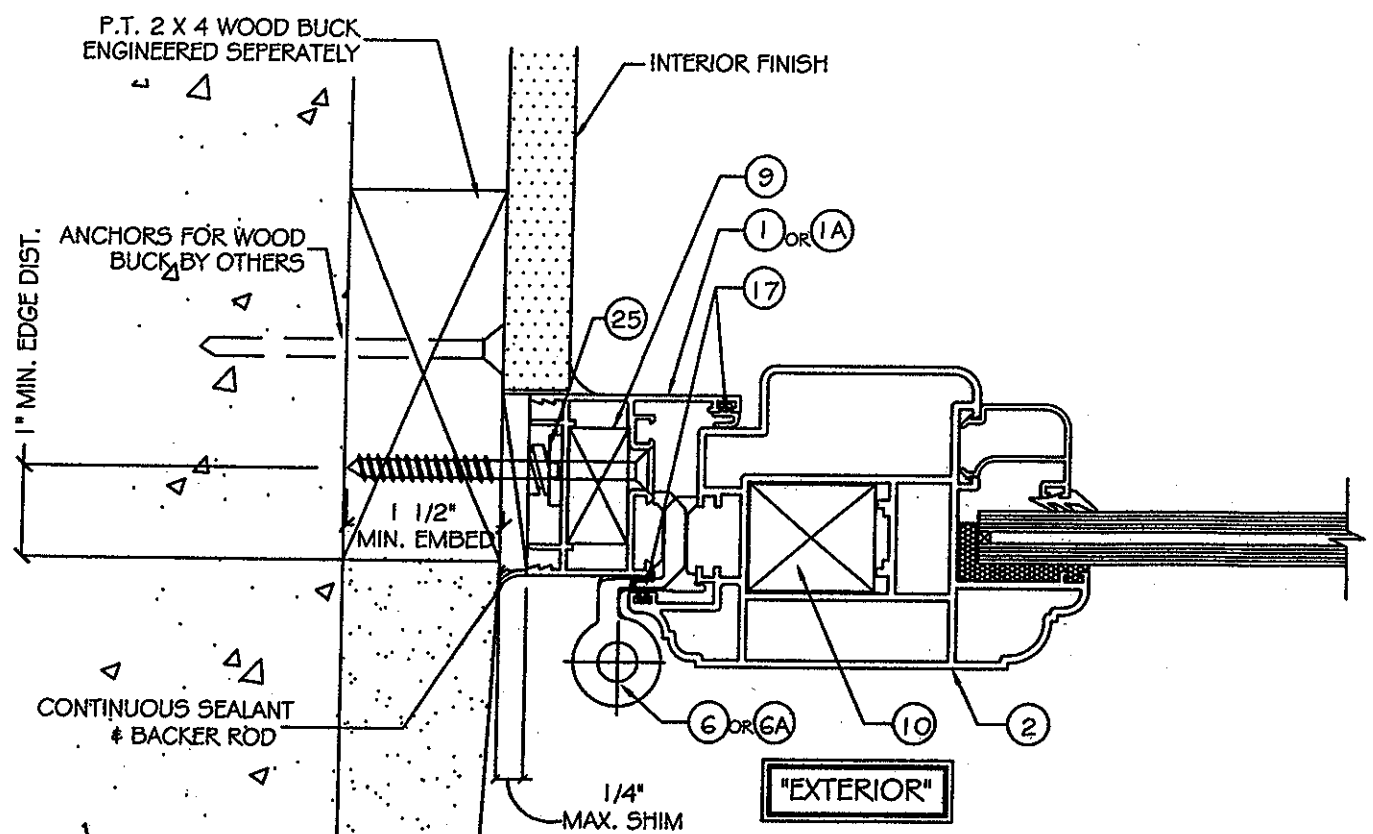

1A JAMB DETAIL (SIMILAR TO HEAD) (WOOD SUBSTRATE)
4 SCALE: 1/4" = 1'-0"

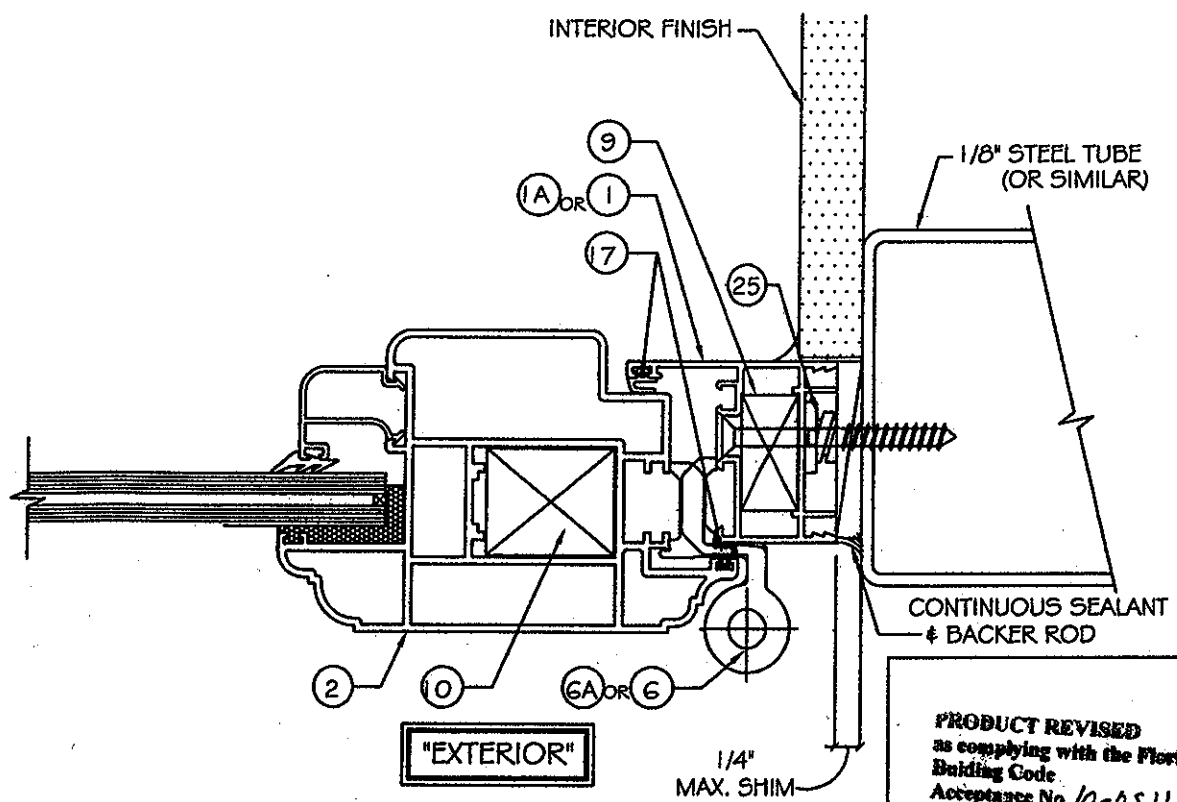

1B JAMB DETAIL (SIMILAR TO HEAD) (METAL SUBSTRATE)
4 SCALE: 1/4" = 1'-0"

PRODUCT REVISED
as complying with the Florida
Building Code
Acceptance No. 10-0511-03
Expiration Date FEB 27, 2013
By *Ishag I. Chaudhry*
Miami Dade Product Control
Division

LA FINESTRA, L.C.
ITALIAN WINDOWS & DOORS
2790 NW 104 COURT
Miami, FL 33172
Phone (305) 599-8093
Fax (305) 592-4671

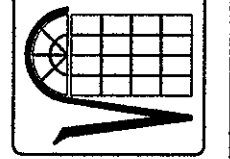

BROMLEY-COOK ENGINEERING, INC.
STRUCTURAL ENGINEERING SERVICES
5440 N.W. 33RD AVENUE, SUITE 100
BOYD (UNDERGROUND) FL 33309
AUG 27 2010
FLORIDA STATE OF P.E. #1380
FLORIDA PROFESSIONAL ENGINEER

PRODUCT:
EKU-53 IMPACT DOORS
HIGH LOAD

DATE: 10/02/2009
SCALE: AS NOTED
DWG. BY: LA FIN
CHK. BY:
DRAWING No.:
FN-EKU53
SHEET: 4 OF 10

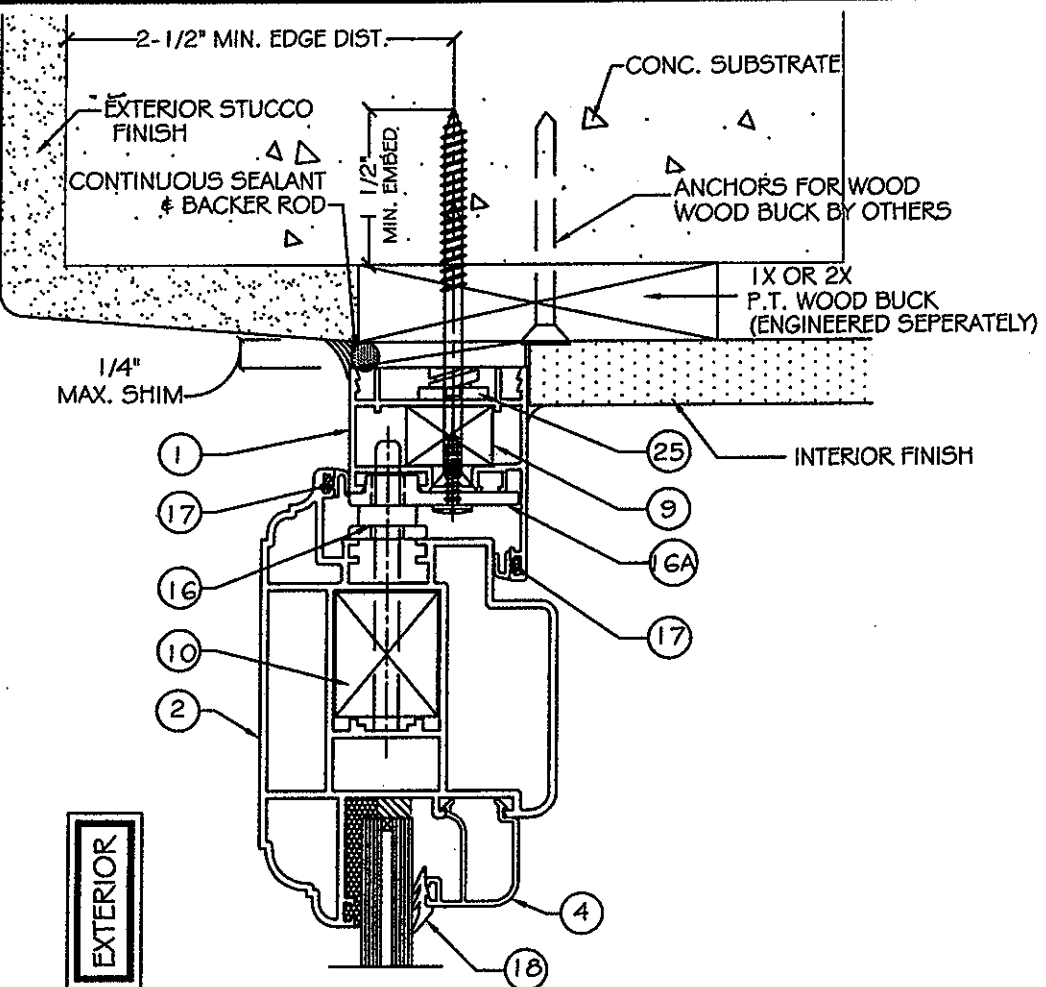

2 HEAD DETAIL (CONC. SUBSTRATE)
5 SCALE: 1/4" = 1'-0"

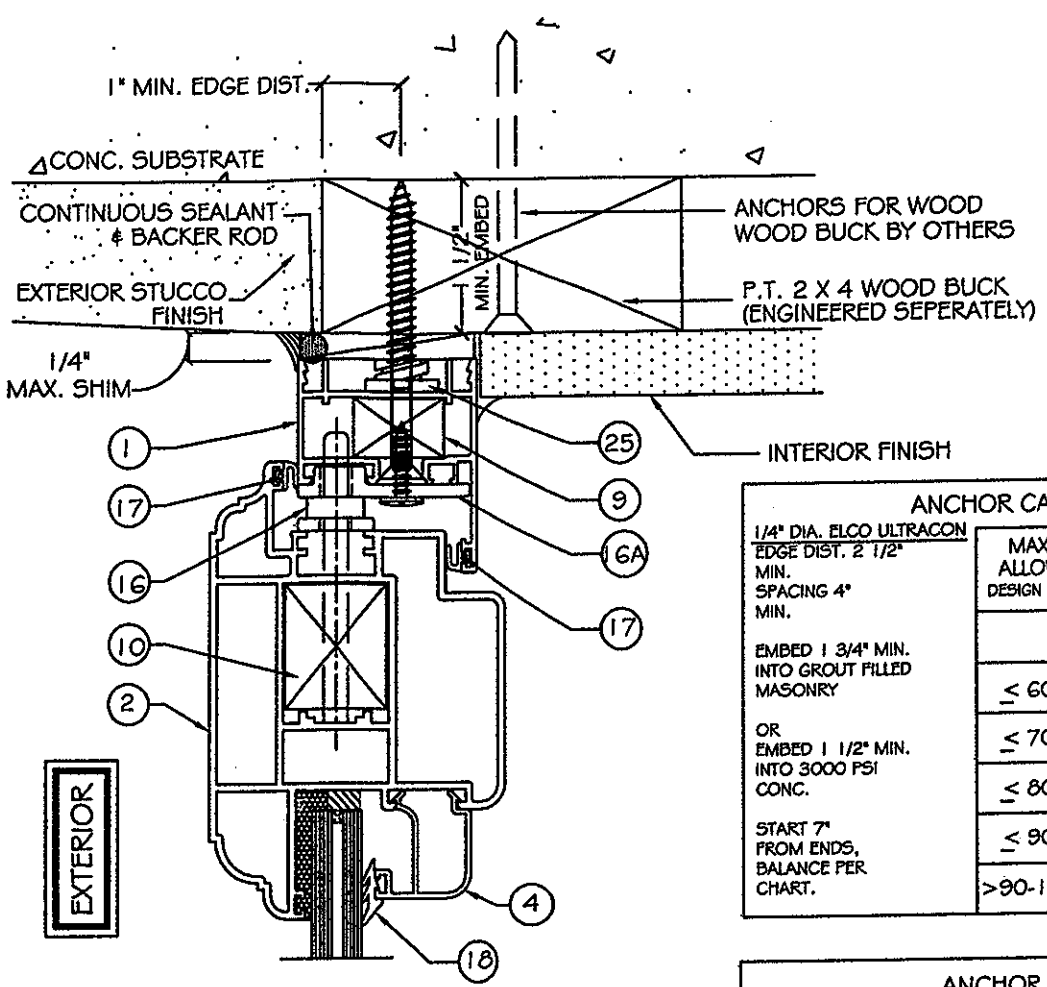

4 HEAD DETAIL (WOOD SUBSTRATE)
5 SCALE: 1/4" = 1'-0"

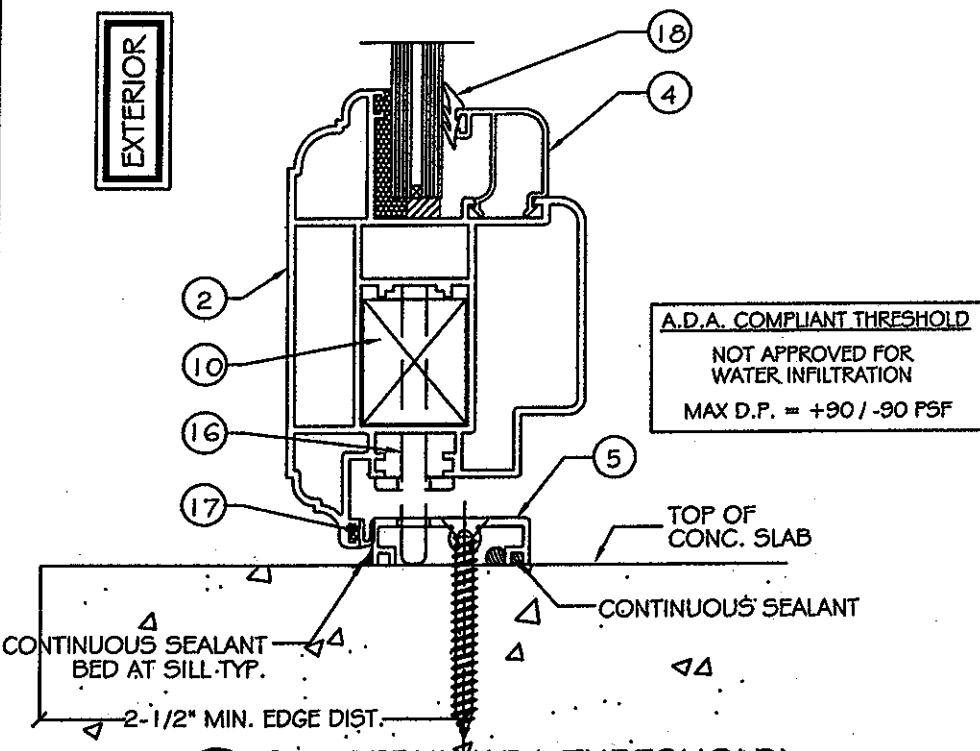

3 SILL DETAIL (ADA THRESHOLD)
5 SCALE: 1/4" = 1'-0"

A.D.A. COMPLIANT THRESHOLD
NOT APPROVED FOR WATER INFILTRATION
MAX D.P. = +90 / -90 PSF

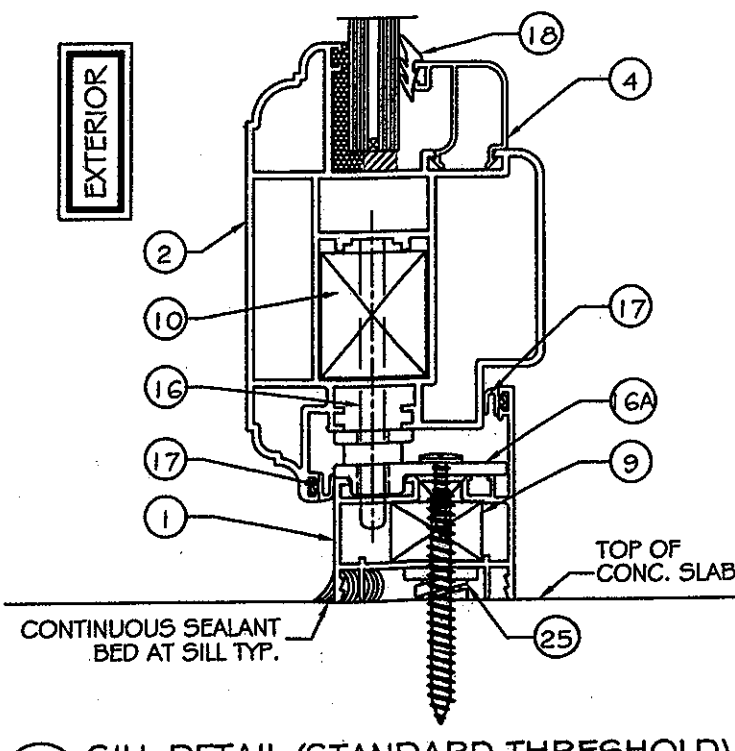

3 SILL DETAIL (STANDARD THRESHOLD)
5 SCALE: 1/4" = 1'-0"

PRODUCT REVISED
as complying with the Florida
Building Code
Acceptance No. 10-0511.03
Expiration Date FEB 27 2013
By Ishag J. Chaudhry
Florida State Product Council
Division

ANCHOR CAPACITY CHART (CONCRETE SUBSTRATE)

1/4" DIA. ELCO ULTRACON
EDGE DIST. 2 1/2"
MIN.
SPACING 4"
MIN.

EMBED 1 3/4" MIN.
INTO GROUT FILLED
MASONRY

OR
EMBED 1 1/2" MIN.
INTO 3000 PSI
CONC.

START 7"
FROM ENDS,
BALANCE PER
CHART.

MAXIMUM ALLOWABLE DESIGN PRESSURE	ANCHORS AT JAMBS	QTY. ANCHORS AT INTERLOCK	
		(W/ FRAME INSERT)	
		UP TO 96"	UP TO 120"
≤ 60 P.S.F.	15-1/2" C/C	2	3
≤ 70 P.S.F.	15-1/2" C/C	2	3
≤ 80 P.S.F.	15-1/2" C/C	3	3
≤ 90 P.S.F.	15-1/2" C/C	3	N/A
>90-110 P.S.F.	15-1/2" C/C	3	N/A

SPACED 4" APART

ANCHOR CAPACITY CHART (STEEL SUBSTRATE)

#14 P.H.S.M.S.
OR
#14 SELF DRILLING

INTO 1/8" THK.
ASTM A36

START 7"
FROM ENDS,
BALANCE PER
CHART.

MAXIMUM ALLOWABLE DESIGN PRESSURE	ANCHORS AT JAMBS	QTY. ANCHORS AT INTERLOCK	
		(W/ FRAME INSERT)	
		UP TO 96"	UP TO 120"
≤ 60 P.S.F.	15-1/2" C/C	2	3
≤ 70 P.S.F.	15-1/2" C/C	2	3
≤ 80 P.S.F.	15-1/2" C/C	3	3
≤ 90 P.S.F.	15-1/2" C/C	3	N/A
>90-110 P.S.F.	15-1/2" C/C	3	N/A

SPACED 2 1/2" APART

ANCHOR CAPACITY CHART (WOOD SUBSTRATE)

#14 P.H.S.M.S.
OR
#14 WOOD SCREW

EMBED 1 1/2" MIN.
INTO NO. 2 SYP.

START 7"
FROM ENDS,
BALANCE PER
CHART.

MAXIMUM ALLOWABLE DESIGN PRESSURE	ANCHORS AT JAMBS	QTY. ANCHORS AT INTERLOCK	
		(W/ FRAME INSERT)	
		UP TO 96"	UP TO 120"
≤ 60 P.S.F.	12" C/C	4	5
≤ 70 P.S.F.	12" C/C	4	5
≤ 80 P.S.F.	12" C/C	5	6
≤ 90 P.S.F.	12" C/C	5	N/A
>90-110 P.S.F.	12" C/C	6	N/A

SPACED 2 1/2" APART

LA FINESTRA, L.C.
ITALIAN WINDOWS & DOORS
2790 NW 104 COURT
Miami, FL 33172
Phone (305) 599-8093
Fax (305) 592-4671

PROFESSIONAL ENGINEER
SEAL
D. SPARTO
P.E. #38967
G.F. #2096

BRIMLEY-COOK ENGINEERING INC.
STRUCTURAL ENGINEERING SERVICE
5440 N.W. 33RD AVENUE, SUITE 100
FORT LAUDERDALE, FL 33309
AUG 27 2008

PRODUCT: EKU-53 IMPACT DOORS
HIGH LOAD

DATE: 10/02/2009
SCALE: 3/16" = 1'-0"
DWG. BY: LA FIN
CHK. BY:

DRAWING No.: FN-EKU53
SHEET: 5 OF 10

PROFILE COMBINATIONS

NOTE: PLEASE SEE D.P. LIMITATIONS FOR GLAZING BEAD ON SHEET 2

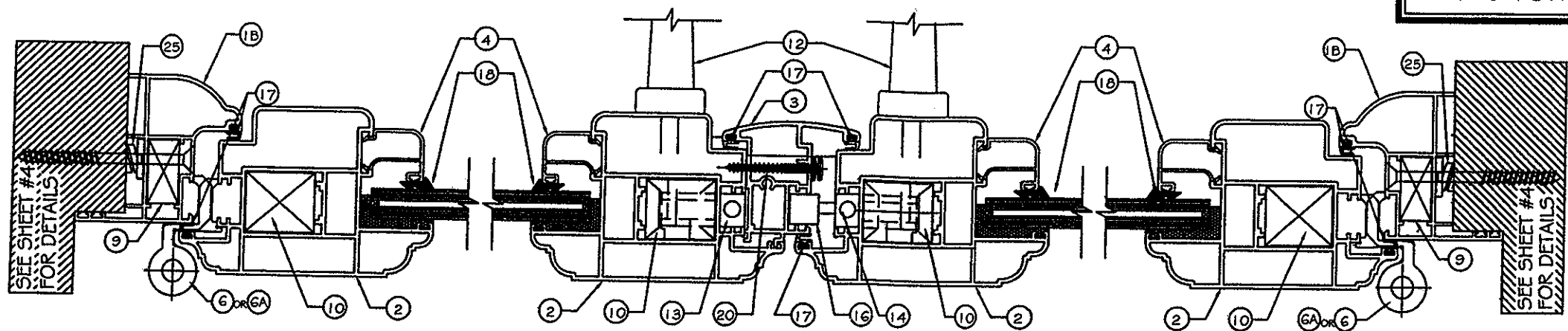

COMBINATION 1
SCALE: 3/16" = 1'-0"

MAXIMUM P.S.F. @ 96" +110.00 -110.00 DESIGN PRESSURE - WATER INFILTRATION TEST PRESSURE = 13.5 PSF
 MAXIMUM P.S.F. @ 120" +80.00 -80.00 DESIGN PRESSURE - WATER INFILTRATION TEST PRESSURE = 12 PSF

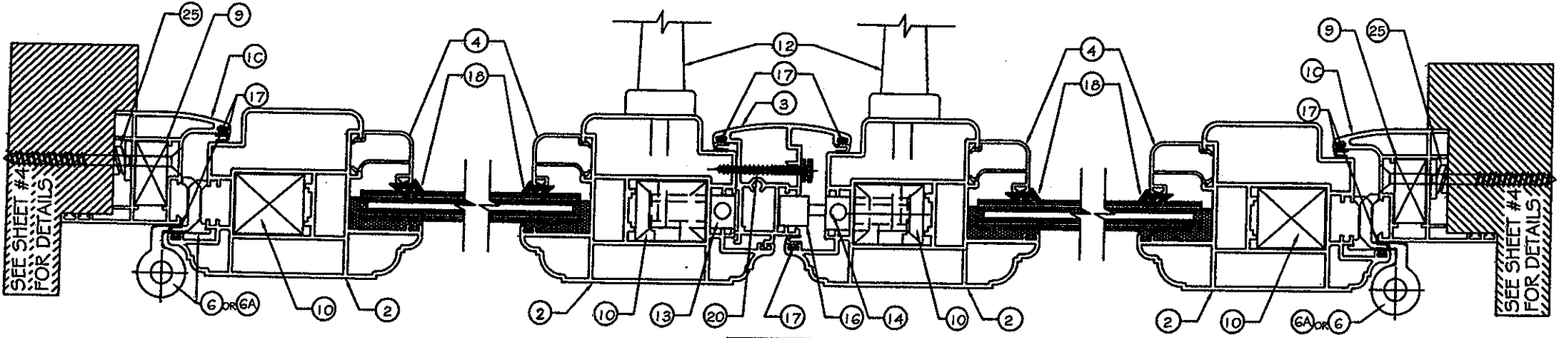

COMBINATION 2
SCALE: 3/16" = 1'-0"

MAXIMUM P.S.F. @ 96" +110.00 -110.00 DESIGN PRESSURE - WATER INFILTRATION TEST PRESSURE = 13.5 PSF
 MAXIMUM P.S.F. @ 120" +80.00 -80.00 DESIGN PRESSURE - WATER INFILTRATION TEST PRESSURE = 12 PSF

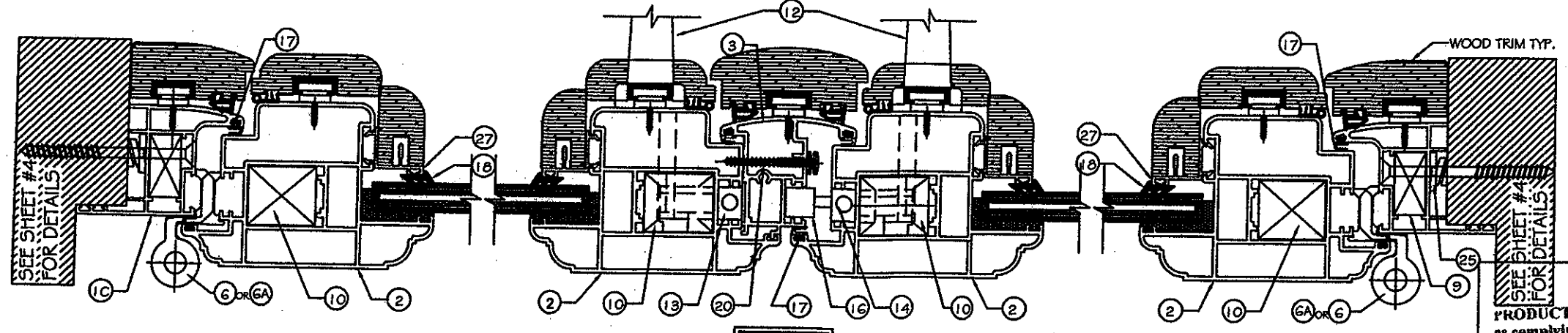

COMBINATION 2 WITH WOOD TRIM
SCALE: 3/16" = 1'-0"

MAXIMUM P.S.F. @ 120" +80.00 -80.00 DESIGN PRESSURE - WATER INFILTRATION TEST PRESSURE = 12 PSF

LA FINESTRA, L.C.
 ITALIAN WINDOWS & DOORS
 2780 NW 104 COURT
 Miami, FL 33172
 Phone (305) 599-8093
 Fax (305) 592-4671

JAM D. BROMLEY, P.E.
 PROFESSIONAL ENGINEER
 BROMLEY-DOGA ENGINEERING, INC.
 STRUCTURAL ENGINEERING SERVICES
 5440 S.W. 33RD AVENUE, SUITE 206
 FORT LAUDERDALE, FL 33309
 AUG 27 2013
 WIDAM IS DRAFT P.E. #49894
 T.F.A. O.B.L. #008

PRODUCT:
EKU-53 IMPACT DOORS
HIGH LOAD

DATE: 10/02/2009
 SCALE: AS NOTED
 DWG. BY: LA FIN
 CHK. BY:

DRAWING No.:
 FN-EKU53
 SHEET: 6 OF 10

PRODUCT REVISED
 as complying with the Florida
 Building Code
 Acceptance No. 10-0511-03
 Expiration Date FEB 27, 2013
 By: *Lehao I. Chumbe*
 Miami Doors Product Control
 Division

PROFILE COMBINATIONS

NOTE: PLEASE SEE D.P. LIMITATIONS FOR GLAZING BEAD ON SHEET 2

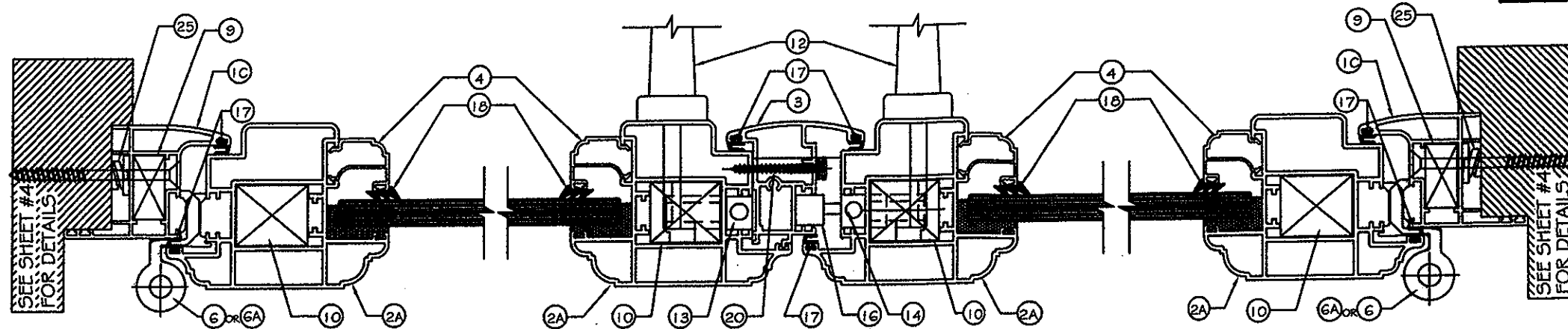

COMBINATION 3
SCALE: 3/16" = 1'-0"

MAXIMUM P.S.F. @ 96" +110.00 -110.00 DESIGN PRESSURE - WATER INFILTRATION TEST PRESSURE = 13.5 PSF
MAXIMUM P.S.F. @ 120" +80.00 -80.00 DESIGN PRESSURE - WATER INFILTRATION TEST PRESSURE = 12 PSF

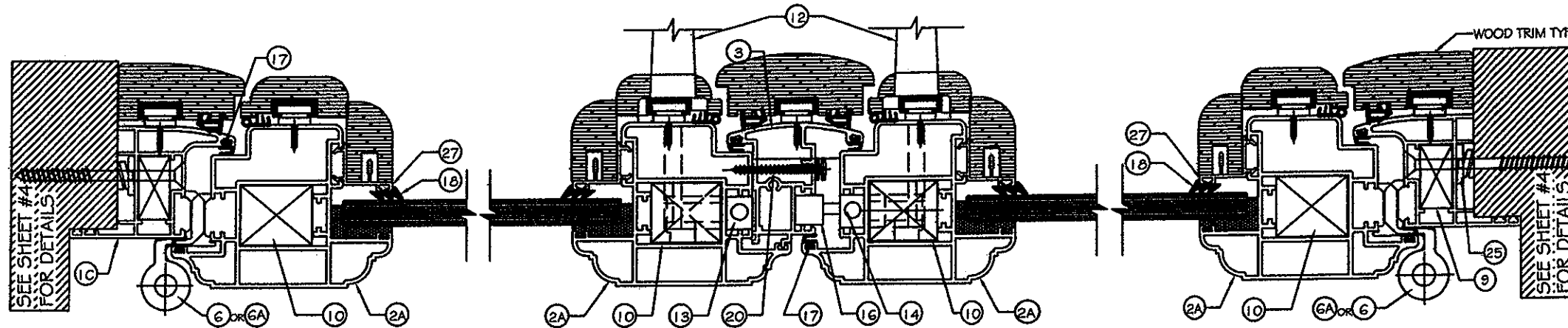

COMBINATION 3 WITH WOOD TRIM
SCALE: 3/16" = 1'-0"

MAXIMUM P.S.F. @ 120" +80.00 -80.00 DESIGN PRESSURE - WATER INFILTRATION TEST PRESSURE = 12 PSF

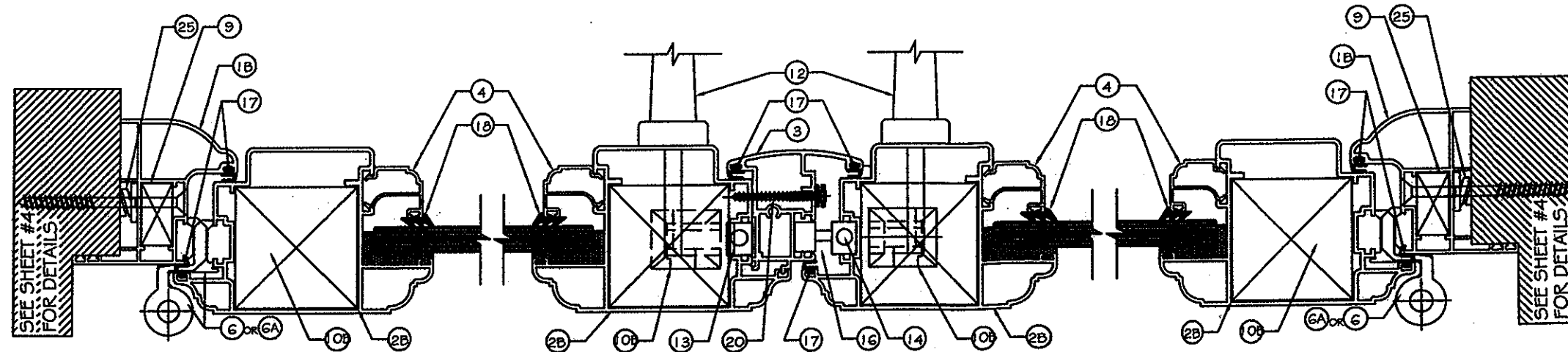

COMBINATION 4
SCALE: 3/16" = 1'-0"

MAXIMUM P.S.F. @ 96" +110.00 -110.00 DESIGN PRESSURE - WATER INFILTRATION TEST PRESSURE = 13.5 PSF
MAXIMUM P.S.F. @ 120" +80.00 -80.00 DESIGN PRESSURE - WATER INFILTRATION TEST PRESSURE = 12 PSF

LA FINESTRA, L.C.
ITALIAN WINDOWS & DOORS
2790 NW 104 COURT
Miami, FL 33172
Phone (305) 599-8093
Fax (305) 592-4671

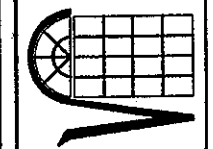

WILLIAM D. COOK ENGINEERING, INC.
BROMLEY-COOK ENGINEERING, INC.
STRUCTURAL ENGINEERING SERVICES
6446 N.W. 33RD AVENUE, SUITE 100
FORT LAUDERDALE, FL 33309
AUG 27 2013
STAMP & SEAL OFFICE #4664
PROFESSIONAL ENGINEER
FL. #10000

PRODUCT: EKU-53 IMPACT DOORS
HIGH LOAD

PRODUCT REVISED
as complying with the Florida
Building Code
Acceptance No. 10-0511.03
Expiration Date FEB 27, 2013
By: *Thomas J. Chene*
Miami Dade Product Control
Division

DATE: 10/02/2009
SCALE: AS NOTED
DWG. BY: LA FIN
CHK. BY:
DRAWING No.: FN-EKU53
SHEET: 7 OF 10

NOTE: PLEASE SEE D.P. LIMITATIONS FOR GLAZING BEAD ON SHEET 2

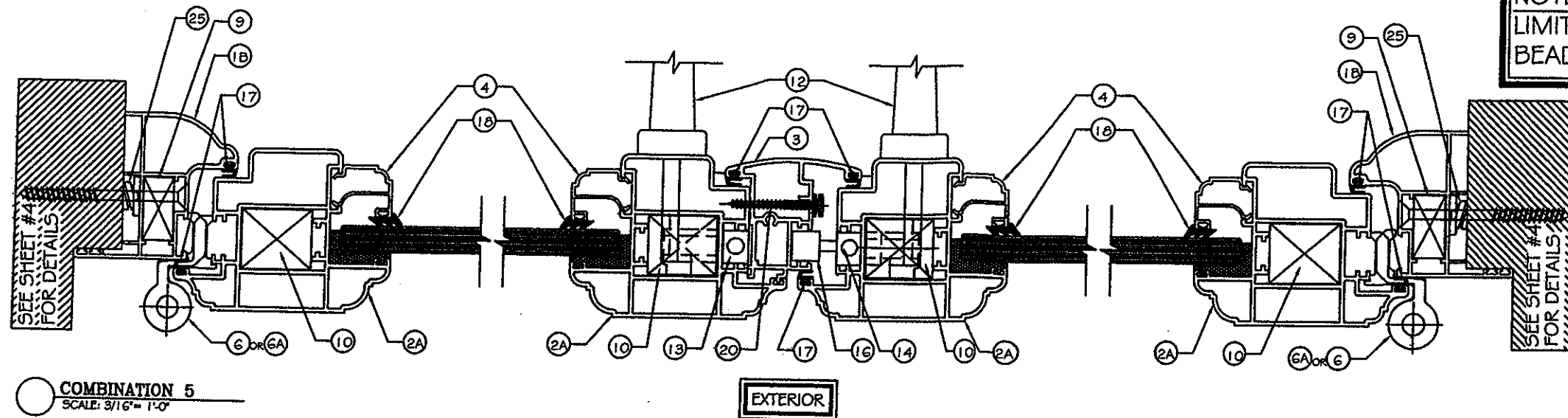

COMBINATION 5
SCALE: 3/16" = 1'-0"

MAXIMUM P.S.F. @ 96" +110.00 -110.00 DESIGN PRESSURE - WATER INFILTRATION TEST PRESSURE = 13.5 PSF
 MAXIMUM P.S.F. @ 120" +80.00 -80.00 DESIGN PRESSURE - WATER INFILTRATION TEST PRESSURE = 12 PSF

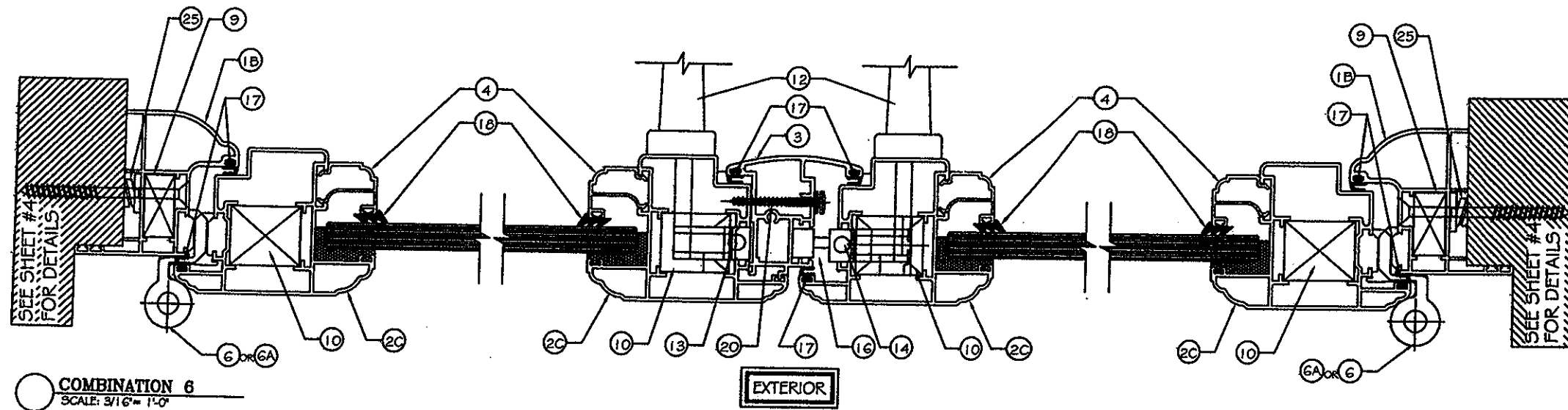

COMBINATION 6
SCALE: 3/16" = 1'-0"

MAXIMUM OF 96" H D.P. = +80 / -80 PSF WATER @ 12 PSF

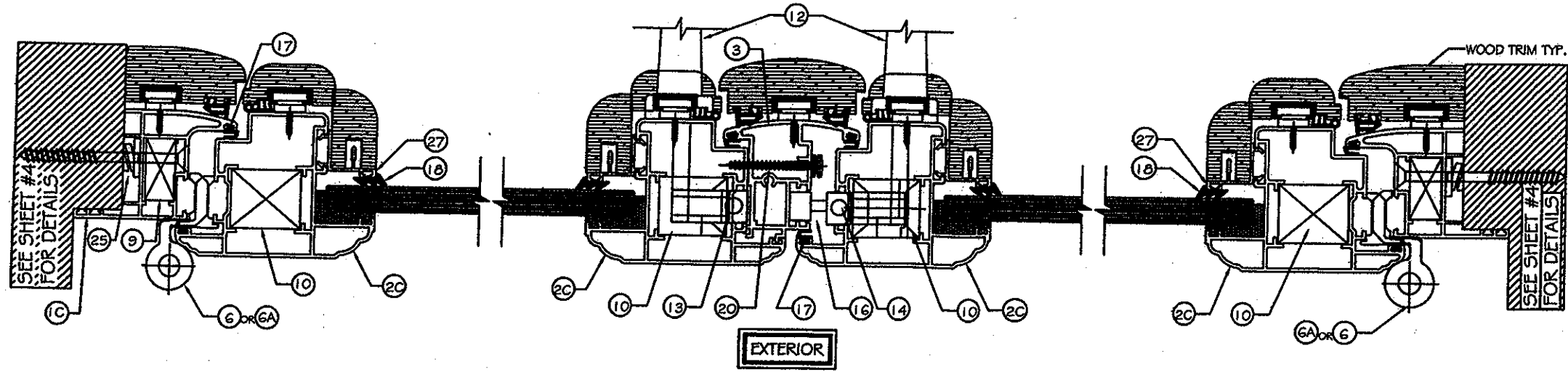

COMBINATION 7 WITH WOOD TRIM
SCALE: 3/16" = 1'-0"
NOTE: WOOD TRIM IS OPTIONAL

MAXIMUM OF 96" H D.P. = +80 / -80 PSF WATER @ 12 PSF

LA FINESTRA, L.C.
ITALIAN WINDOWS & DOORS
2790 NW 104 COURT
Miami, FL 33172
Phone (305) 599-8093
Fax (305) 592-4671

BROMBERG-COOK ENGINEERING, INC.
STRUCTURAL ENGINEERING SERVICES
5440 N.W. 38th Avenue, Suite 200
Fort Lauderdale, FL 33309
AUG 27 2014
MIAMI, FL 33134 P.E. #43994
FLORIDA PROFESSIONAL ENGINEER

PRODUCT: EKU-53 IMPACT DOORS
HIGH LOAD

PRODUCT REVISED
as complying with the Florida
Building Code
Acceptance No. 10-0511-03
Expiration Date FEB 27, 2013
By: *Ishant Chaudhary*
Miami Dade Product Control
Division

DATE: 10/02/2009
SCALE: AS NOTED
DWG. BY: LA FIN
CHK. BY:
DRAWING No.: FN-EKU53
SHEET: 8 OF 10

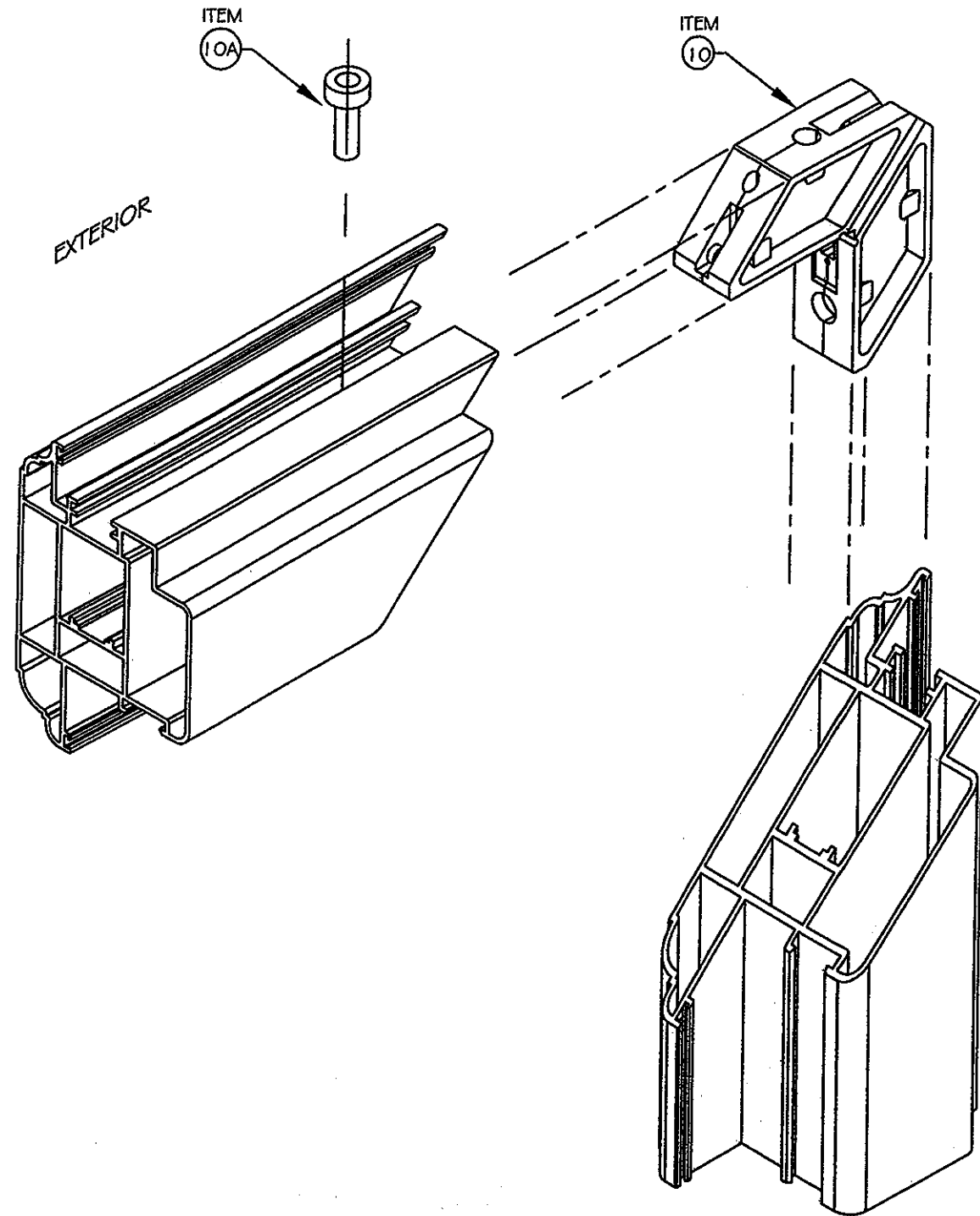

WINDOW PANEL CORNER DETAIL

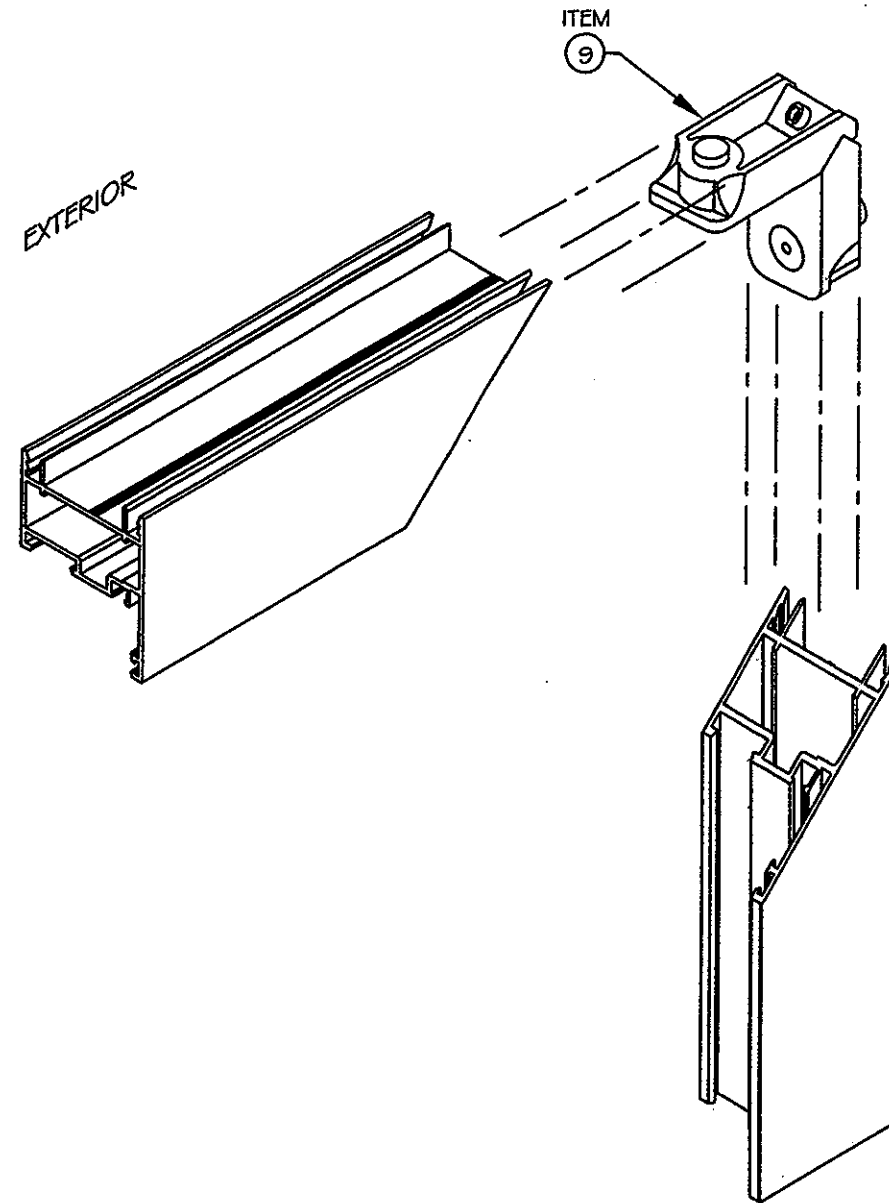

WINDOW FRAME CORNER DETAIL

NOTE: SEAL JOINTS WITH POLYURETHANE SEALANT DURING ASSEMBLY

PRODUCT REVISED as complying with the Florida Building Code
 Acceptance No. 10-0511-03
 Expiration Date FEB 27, 2013
 By *Ischay L. Chayla*
 Miami Dade Product Control Division

LA FINESTRA, L.C.
 ITALIAN WINDOWS & DOORS
 2790 NW 104 COURT
 Miami, FL 33172
 Phone (305) 599-8093
 Fax (305) 592-4671

BROMLEY-COOK ENGINEERING, INC.
 STRUCTURAL ENGINEERING SERVICES
 2440 N.W. 33RD AVENUE SUITE 100
 FORT LAUDERDALE, FL 33309
 AUG 27 2010
 STAFF FILE # 43594
 ST. JOHNS COUNTY

PRODUCT: EKU-53 IMPACT DOORS HIGH LOAD

DATE: 10/02/2009
 SCALE: AS NOTED
 DWG. BY: LA FIN
 CHK. BY:
 DRAWING No.: FN-EKU53
 SHEET 9 OF 10

BILL OF MATERIALS

ITEM	PART No.	QUANTITY	DESCRIPTION	MATERIAL	LOCATION	MANUFACTURER
1	7011	4	FRAME HEAD/JAMB/RESIDENTIAL SILL	AL.AL. -6060-T5	DOOR FRAME	PROFILATI SpA
1A	7012	4	FRAME HEAD/JAMB/RESIDENTIAL SILL	AL.AL. -6060-T5	DOOR FRAME	PROFILATI SpA
1B	17948	4	FRAME HEAD/JAMB/RESIDENTIAL SILL	AL.AL. -6063-T5	DOOR FRAME	PROFILATI SpA
1C	17949	4	FRAME HEAD/JAMB/RESIDENTIAL SILL	AL.AL. -6063-T5	DOOR FRAME	PROFILATI SpA
2	Z16012	4	PANEL HEAD/JAMB/SILL	AL.AL. -6060-T5	DOOR PANEL	PROFILATI SpA
2A	Z16013	4	PANEL HEAD/JAMB/SILL	AL.AL. -6063-T5	DOOR PANEL	PROFILATI SpA
2B	Z19678	4	PANEL HEAD/JAMB/SILL	AL.AL. -6063-T5	DOOR PANEL	PROFILATI SpA
2C	Z18853	4	PANEL HEAD/JAMB/SILL	AL.AL. -6063-T5	DOOR PANEL	PROFILATI SpA
3	Z16014	1	ASTRAGAL	AL.AL. -6060-T5	INACTIVE LEAF PANEL JAMB	PROFILATI SpA
4	4195	4/VENT	GLAZING BEAD	AL.AL. -6060-T5	PANEL PERIMETER	PROFILATI SpA
5	6009	1	COMMERCIAL THRESHOLD	AL.AL. -6060-T5	THRESHOLD	PROFILATI SpA
6	A8221	6/VENT	4" BUTTHINGES	AL.AL. -6060-T5	PANEL AND FRAME JAMBS	MASTER
6A	160/12	6/VENT	4" BUTTHINGES	AL.AL. -6060-T5	PANEL AND FRAME JAMBS	CASALI
7	N/A	2 EA. LITE OF GLASS	1/4" X 1/2" X 3" LG. SETTING BLOCK	EXTRUDED SILICONE	Ø 6" FROM ENDS	GENERIC
9	0409	1 EA. CORNER	FRAME CORNER KEY	CAST ALUMINUM	FRAME CORNERS	MONTICELLI
10	5004	1 EA. CORNER	PANEL CORNER KEY	CAST ALUMINUM	PANEL CORNERS	MONTICELLI
10A	001	1 EA. CORNER	PANEL CORNER KEY	EXT. ALUMINUM	PANEL CORNERS	PROFILATI SpA
10B	002	1 EA. CORNER	PANEL CORNER KEY	EXT. ALUMINUM	PANEL CORNERS	PROFILATI SpA
12	SERIES 800	1/VENT	OPERATING HANDLE	ALUMINUM	EACH PANEL JAMB	PASINI
13	1025	2	TRANSMISSION MOVEMENT DEVISE	ZAMA/S.S.	PANEL JAMB ASTRAGAL SIDE ONLY	GSG
14	1286		5-POINT LOCKING SYSTEM	S.S.	ACTIVE PANEL	AMESBURY
15	FB-1300-20-SS	2	FLUSH BOLT	S.S.	ACTIVE PANEL	SULLIVAN
16	4031	AS SHOWN	MUSHROOM HEAD AND KEEPERS	S.S./ALUMINUM	PANEL JAMB AT TOP & BOTTOM	GSG/LAFIN
16A	CD-MPK-100-SS		MULTIPOINT KEEPER KIT	S.S./ALUMINUM	PANEL JAMB AT TOP & BOTTOM	SULLIVAN
17	2666	AS REQ'D.	WEATHERSTRIP GASKET	EPDM	FRAME JAMB/ASTRAGAL/FRAME PANEL	PROFILATI SpA
18	002/009	AS REQ'D.	WEDGE GASKET	EPDM	PANEL GLAZING PERIM. (INTERIOR)	PROFILATI SpA
19	----	2/EACH	# 10 x 2 1/2" FH.SMS. (ASSEMBLY)	PLATED STEEL	FLUSHBOLT STRIKE PLATE	----
20	----	SEE ELEV.	# 8 x 1 1/2" FH.SMS. (ASSEMBLY)	PLATED STEEL	ASTRAGAL (SINGLE ROW)	----
22	----	2 EA. CORNER	#14 X 3/4" FH. SMS. (PANEL ASS'Y)	PLATED STEEL	PANEL CORNERS	----
23	895/995	CONTINUOUS	STRUCTURAL SILICONE	SILICONE	PERIMETER GLASS TO METAL	PECORA OR DOW CORNING
25	CD.100.BK	AS REQ'D.	FRAME INSERT	ALLUM/NYLON	FRAME PERIMETER (SINGLE ROW)	SULLIVAN
26	SDG.SP.316	AS REQ'D.	STRIKE PLATE	S.S.	ALONGSIDE FRAME (WHERE LOCK MEETS)	SULLIVAN
27	092109	4/VENT	GLAZING BEAD	AL.AL. -6060-T5	PANEL PERIMETER	PROFILATI SpA
28	4293	4/VENT	GLAZING BEAD	AL.AL. -6060-T5	PANEL PERIMETER	PROFILATI SpA
29	2167/2168	2	FLUSH BOLT	ZAMA	INACTIVE PANEL	GSG

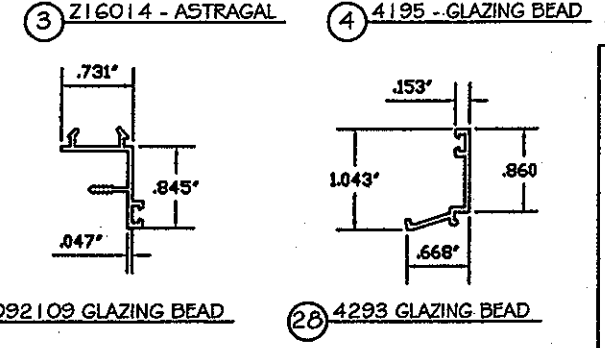
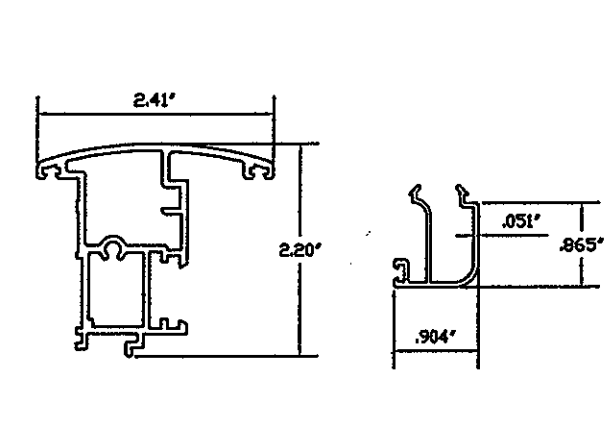
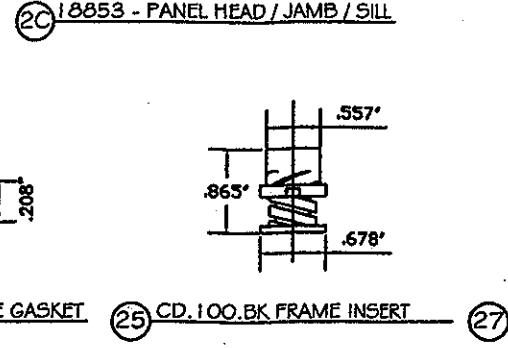
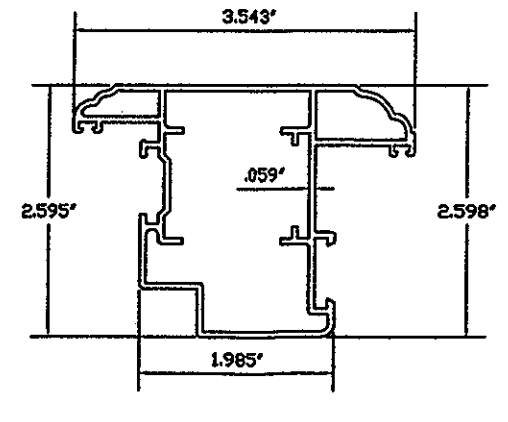
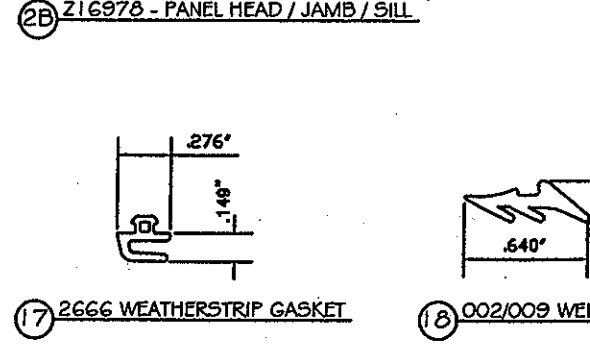
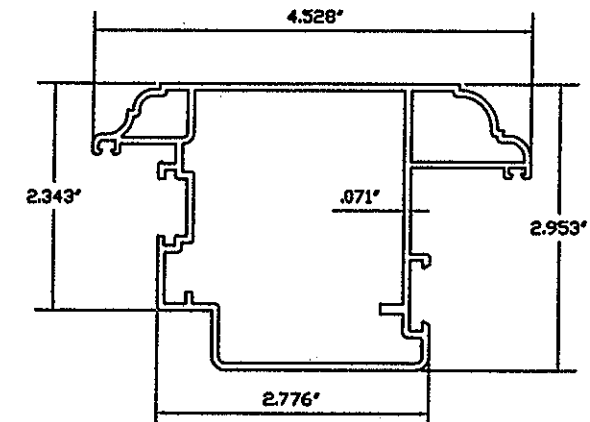
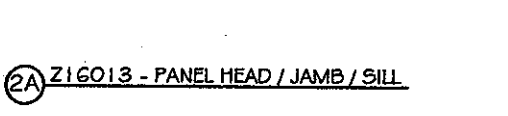
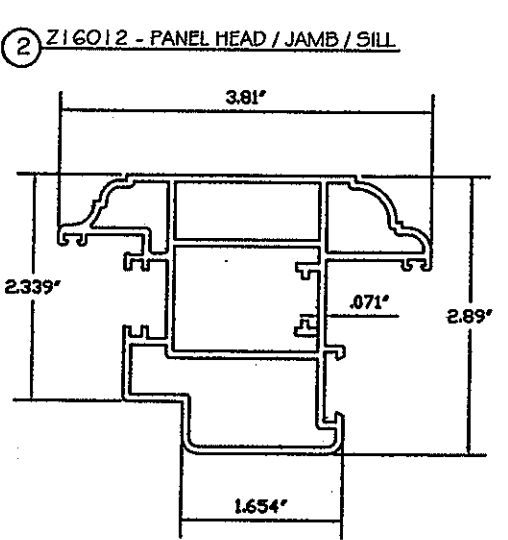
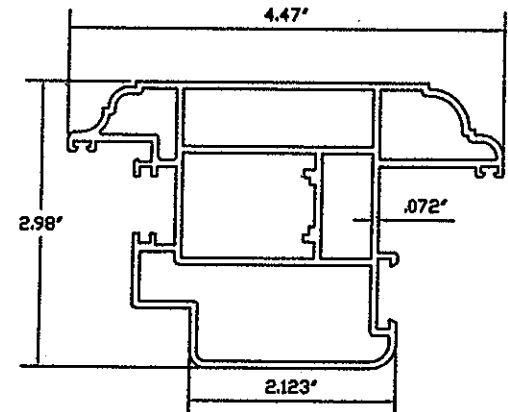
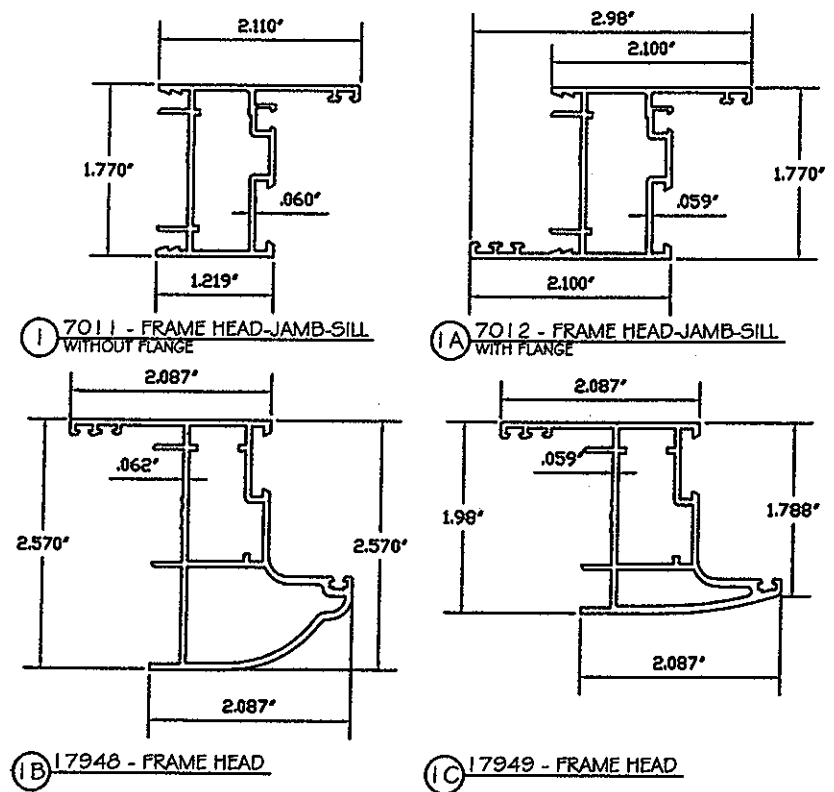

NOT USED: (8) (21)
(11) (24)

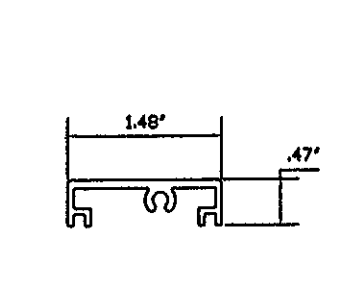

PRODUCT REVISED as complying with the Florida Building Code
Acceptance No. 10-0511.03
Expiration Date FEB 27, 2013
By Isaac I. Chanda
Miami Dade Product Control Division

LA FINESTRA, L.C.
ITALIAN WINDOWS & DOORS
2790 NW 104 COURT
Miami, FL 33172
Phone (305) 599-8093
Fax (305) 592-4671

BROMLEY & CO'S ENGINEERING, INC.
STRUCTURAL ENGINEERING SERVICES
3440 NW 36TH AVENUE, SUITE 200
MIAMI, FLORIDA 33142
TEL: (305) 441-3309
FAX: (305) 441-3308
AUG 27 2008
FLORIDA STATE OF EST. 1930
PROFESSIONAL ENGINEER

PRODUCT: **EKU-53 IMPACT DOORS**
HIGH LOAD

DATE: 10/02/2008
SCALE: AS NOTED
DWG. BY: LA FIN
CHK. BY:
DRAWING No.: FN-EKU53
SHEET: 10 OF 10